

**GROUP 400
CHECK
VALVES
MOD.
460B/28**

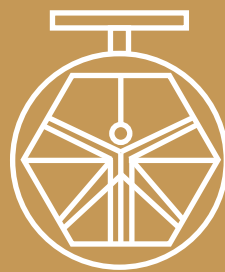

**DAVINCI
VALVES™**

TECHNICAL DATA SHEET

WATER Series

FOOT/AXIAL CHECK VALVES

**DAVINCI
VALVES™**



**QUALITY
ASSUREMENT**

**DAVINCI
VALVES™**



**PRODUCT QT
ASSUREMENT**

**DAVINCI
VALVES™**



**COMPANY QT
ASSUREMENT**

www.davincivalves.com

18 Dongyu Street, Square One,
11th Floor 1101, Jinjiang District,
Chengdu, Sichuan CHINA

10F/Tower A, Billion Center,
1 Wang Kwong Road, Kowloon Bay
Kowloon HONG KONG

FOOT CHECK VALVE FLANGED END

Ref.460B / PN 10-16

APPLICATION:

Mainly used for Fresh Water, Sea water, all kinds of oil, acid, alkaline liquid etc

GENERAL CHARACTERISTICS:

Range from ND50 up to ND300.

WRAS certificate for Drinking Water (Rubber and paint) available

Minimum head loss.

Epoxy paint 250 microns: RAL 5015.

WORKING CONDITIONS:

Pressure Ratings: 1.0Mpa; 1.6Mpa

Working Temperature: NBR -10C° +80C°

EPDM -10C° +120C°

Flow Media: Fresh Water, Sea water, all kinds of oil, acid, alkaline liquid

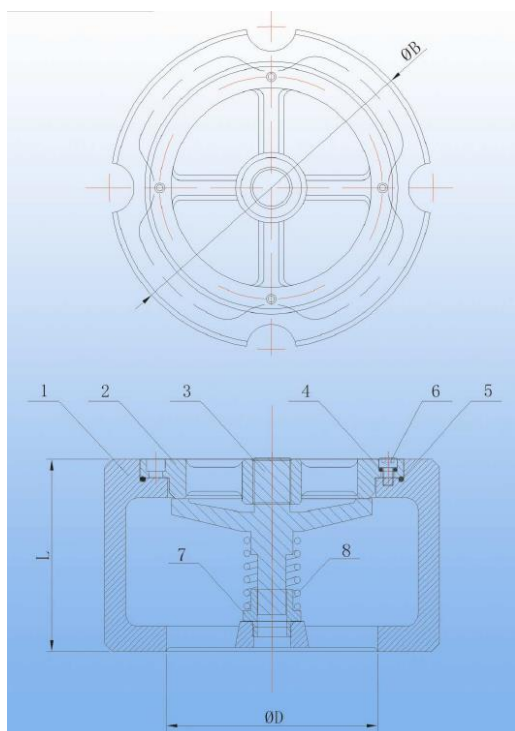

STANDARDS:

End Connections: PN10, PN16.

Comply with EN 558-1, ISO 5752

and EN 1092-2, ISO 7005-2 flange dimension.

Pressure test according to standards: API598

DIN3230 EN12266-1

DN(mm)	L(mm)	ΦD(mm)	ΦB(mm)
50	67	59	108
65	73	80	127
80	79	84	146
100	102	112	174
125	117	130	213
150	140	164	248
200	165	216	340
250	210	250	406
300	286	300	482

No.	Part	Material
1	Body	GG25/GGG40
2	Guide	SS304/316
3	Disc	SS304/316
4	O-Ring	NBR/EPDM
5	Seat ring	NBR/EPDM
6	Bolts	SS304/316
7	Sleeve	SS304/316
8	Spring	SS304/316

All the components can be substituted with equivalent or higher-class materials.

DAVINCI VALVES LTD, is constantly looking at all ways of improving our products and services related to the water, fire and industry sector and therefore we reserve the right to change, without prior notice, any of the data contained here. Please contact our Technical Sales Department for detailed advice.
© 2018 DAVINCI VALVES LTD.

"For professionals who wants more"



DAVINCI
VALVES™